

## 4-Channel LED Driver with Open/Short LED Detection

### FEATURES

- Quad-mode charge pump: 1x, 1.33x, 1.5x, 2x
- Drives up to 4 LEDs at 30mA each
- Pin compatible with industry standard '604
- Open/short LED automatic detection
- Power efficiency up to 92%
- High resolution PWM dimming
- Low noise supply ripple in all modes
- Soft start and current limiting
- Short circuit and thermal overload protection
- 16-Pad TQFN package, 4mm x 4mm

### APPLICATION

- LCD Display Backlight
- Cellular Phones
- Digital Still Cameras
- Handheld Devices

### ORDERING INFORMATION

Part Number	Package	Qty per Reel	Marking
SET3604VHV4-GT2	TQFN-16 <sup>(1)</sup> 4 x 4mm	2000	CDAK
SET3604VHV4-T2	TQFN-16 4 x 4mm	2000	CDAF

**Note:**

(1) NiPdAu Plated Finish, RoHS compliant  
For other finishes, please contact factory

**For Ordering Information details, see page 14.**

### PIN CONFIGURATION

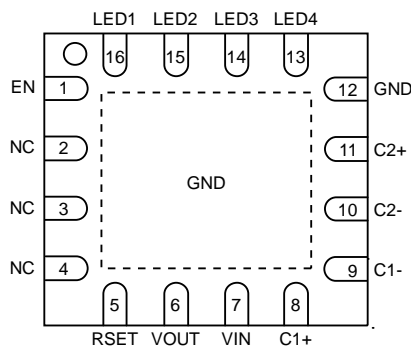

### DESCRIPTION

The new product SET3604V is a high efficiency fractional charge pump that can drive up to four LEDs with input supply voltages as low as 2.5V.

An external RSET resistor is used to control the LED channel brightness while channel diagnostics include automatic detection for both short and open LED channel conditions, ensuring the SET3604V maintains the highest efficiency level in all operating modes.

Each operating mode uses a constant high frequency switching scheme which allows the use of small form factor external ceramic capacitors while delivering excellent low noise input supply ripple up to 5.5 volts.

The EN input control supports direct PWM dimming and can accommodate dimming frequencies in excess of 10kHz thereby providing extremely high resolution brightness levels.

The device is available in the 16-pad low profile 0.8mm thin QFN (4mm x 4mm).

### TYPICAL APPLICATION CIRCUIT

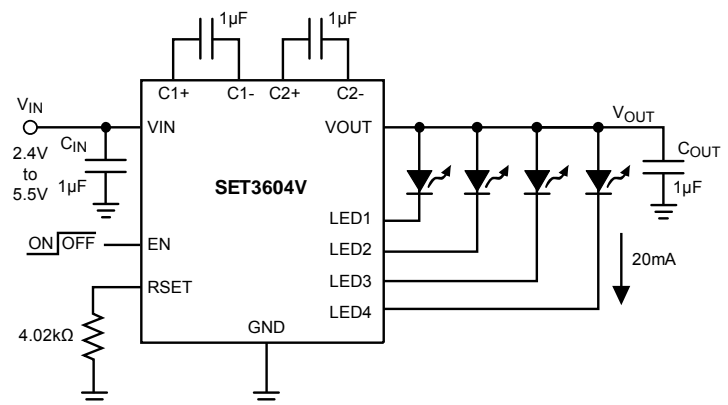

## ABSOLUTE MAXIMUM RATINGS

Parameter	Rating	Unit
V <sub>IN</sub> , LED <sub>x</sub> , C1 <sub>±</sub> , C2 <sub>±</sub> voltage	6	V
V <sub>OUT</sub> voltage	7	V
EN voltage	6	V
Storage Temperature Range	-65 to +160	°C
Junction Temperature Range	-40 to +150	°C
Lead Temperature	300	°C

## RECOMMENDED OPERATING CONDITIONS

Parameter	Rating	Unit
V <sub>IN</sub>	2.5 to 5.5	V
Ambient Temperature Range	-40 to +85	°C
I <sub>LED</sub> per LED pin	0 to 25	mA
Total Output Current	0 to 100	mA
LED Forward Voltage Range	1.3 to 4.3	V

Typical application circuit with external components is shown on page 1.

## ELECTRICAL OPERATING CHARACTERISTICS

(over recommended operating conditions unless specified otherwise) V<sub>IN</sub> = 3.6V, EN = High, T<sub>AMB</sub> = 25°C

Symbol	Name	Conditions	Min	Typ	Max	Units	
I <sub>Q</sub>	Quiescent Current	1x mode, no load		1.0		mA	
		1.33x mode, no load		1.7		mA	
		1.5x mode, no load		2.2		mA	
		2x mode, no load		2.4		mA	
I <sub>QSHDN</sub>	Shutdown Current	V <sub>EN</sub> = 0V			1	µA	
I <sub>LED-ACC</sub>	LED Current Accuracy	I <sub>LEDAVG</sub> / I <sub>LEDAVG-NOMINAL</sub>		±2		%	
I <sub>LED-DEV</sub>	LED Channel Matching	(I <sub>LED</sub> - I <sub>LEDAVG</sub> ) / I <sub>LEDAVG</sub>		±1.5		%	
I <sub>LED</sub>	Programmed LED Current	R <sub>SET</sub> = 34.0kΩ		2.4		mA	
		R <sub>SET</sub> = 5.23kΩ		15			
		R <sub>SET</sub> = 2.67kΩ		30			
V <sub>RSET</sub>	RSET Regulated Voltage		0.58	0.6	0.62	V	
R <sub>OUT</sub>	Output Resistance (open loop)	1x mode		0.8		Ω	
		1.33x mode, V <sub>IN</sub> = 3V		5		Ω	
		1.5x mode, V <sub>IN</sub> = 2.7V		5		Ω	
		2x mode, V <sub>IN</sub> = 2.4V		10		Ω	
F <sub>OSC</sub>	Charge Pump Frequency	1.33x and 2x mode	0.8	1	1.3	MHz	
		1.5x mode	1	1.3	1.6	MHz	
I <sub>SC_MAX</sub>	Output short circuit Current Limit	V <sub>OUT</sub> < 0.5V		50		mA	
I <sub>IN_MAX</sub>	Input Current Limit	V <sub>OUT</sub> > 1V		250		mA	
LED <sub>TH</sub>	1x to 1.33x, 1.33x to 1.5x or 1.5x to 2x Transition Thresholds at any LED pin			130		mV	
V <sub>HYS</sub>	1x Mode Transition Hysteresis			400		mV	
R <sub>EN</sub>	EN Pin <ul style="list-style-type: none"> <li>Internal Pull-down Resistor</li> <li>Logic High Level</li> <li>Logic Low Level</li> </ul>		1.3	100		kΩ	
V <sub>HI</sub>							V
V <sub>LO</sub>						0.4	V
T <sub>SD</sub>	Thermal Shutdown			150		°C	
T <sub>HYS</sub>	Thermal Hysteresis			20		°C	
V <sub>UVLO</sub>	Undervoltage lockout (UVLO) threshold		1.6	1.8	2.0	V	

### A.C. CHARACTERISTICS

For  $2.5V \leq V_{IN} \leq 5.5V$ , over full ambient temperature range  $-40$  to  $+85^{\circ}C$ .

Symbol	Name	Conditions	Min	Typ	Max	Units
$T_{LED}$	LED current settling time from shutdown mode	1x mode, $V_{IN} = 4V$ 1.33x mode, $V_{IN} = 3.5V$		40 400		$\mu s$
$T_{MD}$	Mode transition time			500		$\mu s$
$T_{PWRDWN}$	Device power down delay			0.9	1.5	ms
$T_{LED-ON}$	LED on settling time			1		$\mu s$
$T_{LED-OFF}$	LED off settling time			120		ns

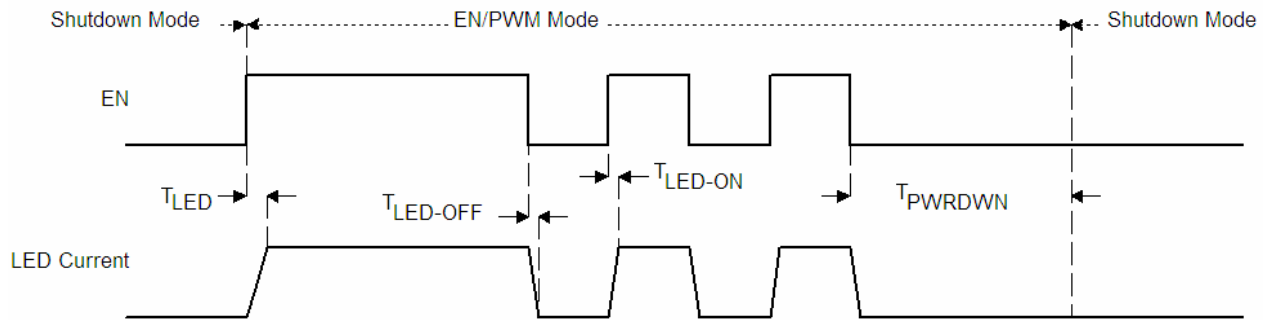

Figure 1. SET3604V Timing Characteristics

### LED Current Setting

The nominal LED current is set by the external resistor connected between the RSET pin and ground. Table 1 lists standard resistor values for several LED current settings.

LED current (mA)	RSET (k $\Omega$ )
2	40.0
5	15.8
10	7.87
15	5.23
20	4.02
25	3.16
30	2.67

Table 1. Resistor RSET and LED current

**TYPICAL PERFORMANCE CHARACTERISTICS**

$V_{IN} = 3.6V$ ,  $I_{OUT} = 80mA$  (4 LEDs at 20mA),  $C_{IN} = C_{OUT} = C_1 = C_2 = 1\mu F$ ,  $T_{AMB} = 25^{\circ}C$  unless otherwise specified.

**Efficiency vs. Input Voltage**

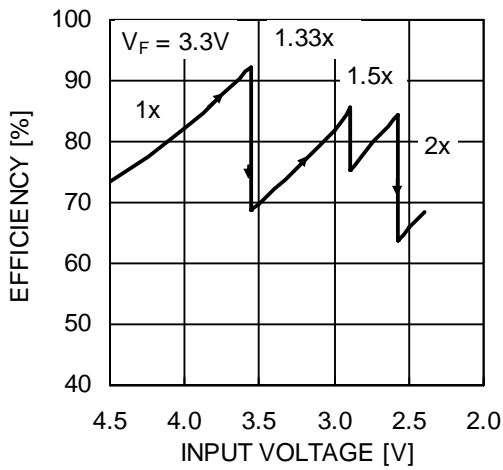

**Efficiency vs. Li-Ion Voltage**

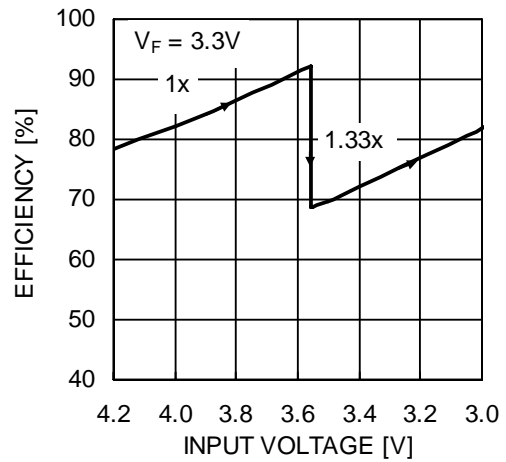

**Quiescent Current vs. Input Voltage**

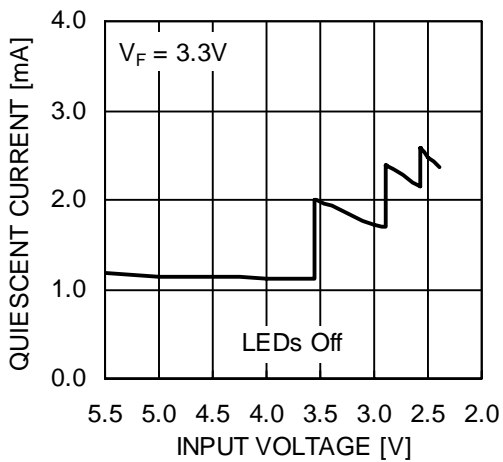

**Quiescent Current vs. Temperature**

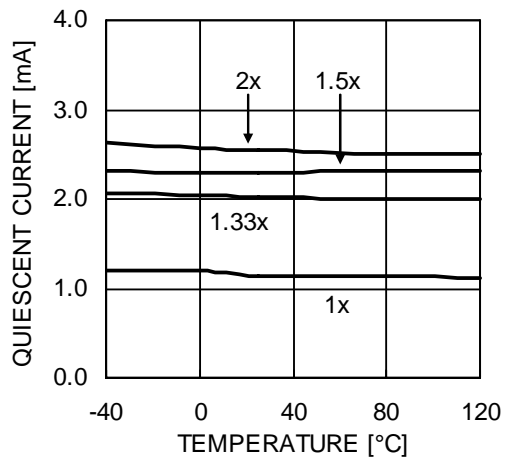

**LED Current Change vs. Input Voltage**

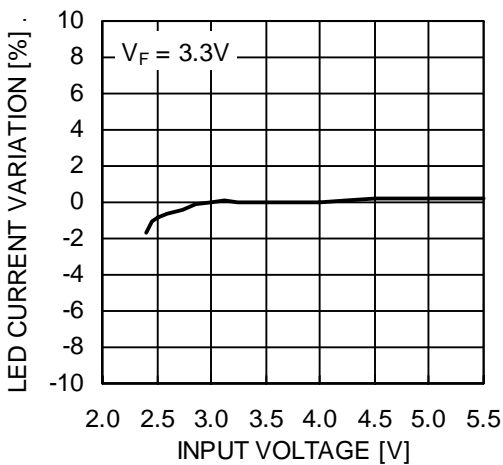

**LED Current Change vs. Temperature**

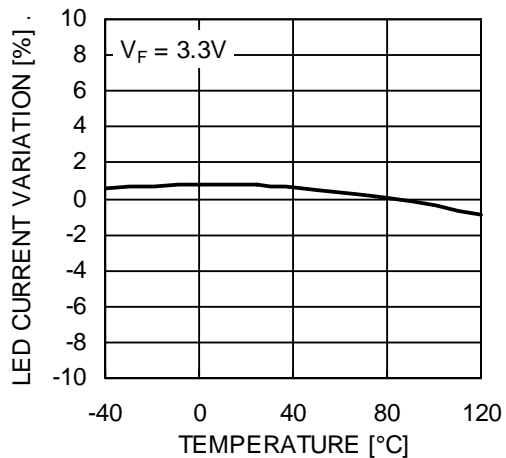

### TYPICAL PERFORMANCE CHARACTERISTICS

$V_{IN} = 3.6V$ ,  $I_{OUT} = 80mA$  (4 LEDs at 20mA),  $C_{IN} = C_{OUT} = C_1 = C_2 = 1\mu F$ ,  $T_{AMB} = 25^{\circ}C$  unless otherwise specified.

**Switching Frequency vs. Temperature**

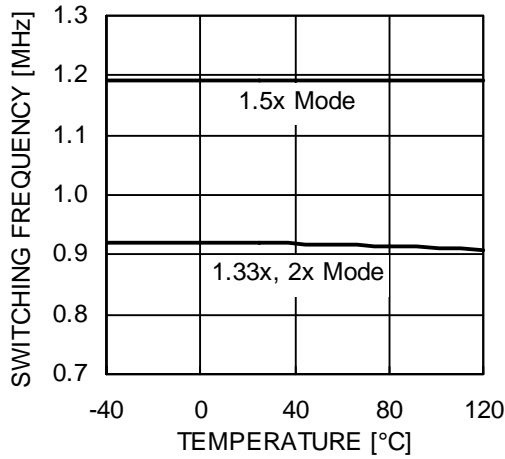

**Output Resistance vs. Input Voltage**

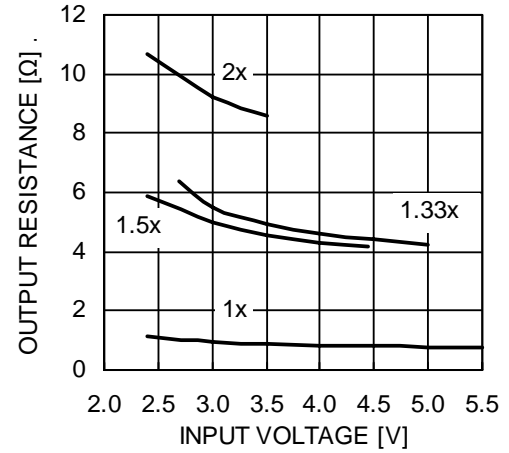

**Foldback Current Limit**

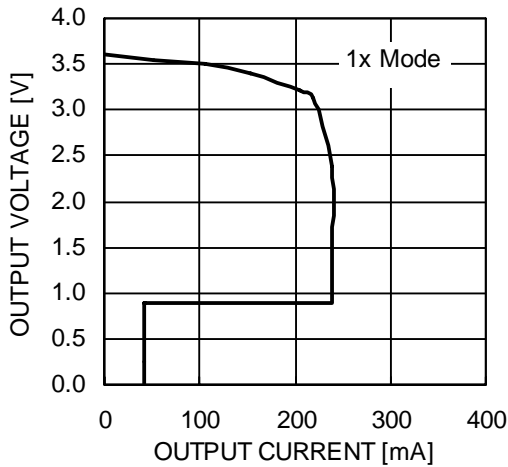

**LED Current vs. LED Pin Voltage**

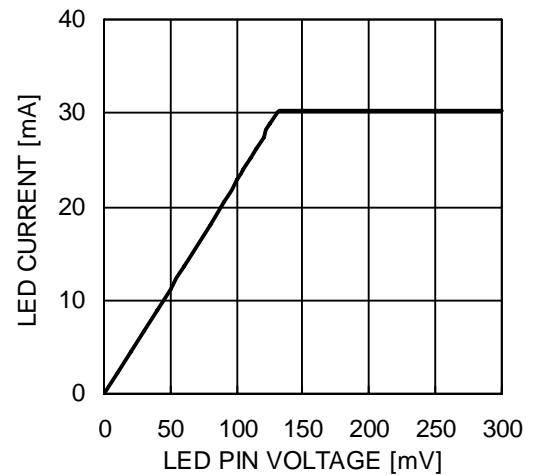

**LED Current vs. RSET Resistance**

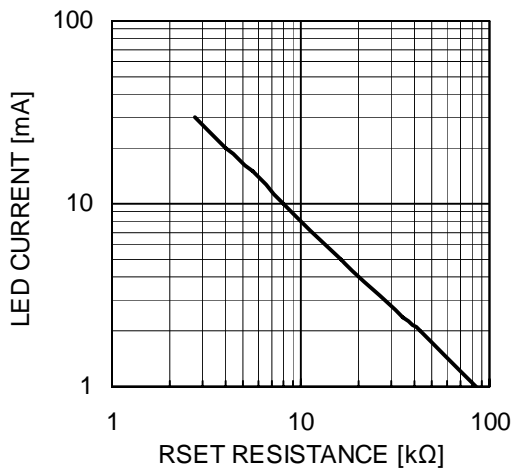

**Line Transient Response (3.6V to 4.9V)**

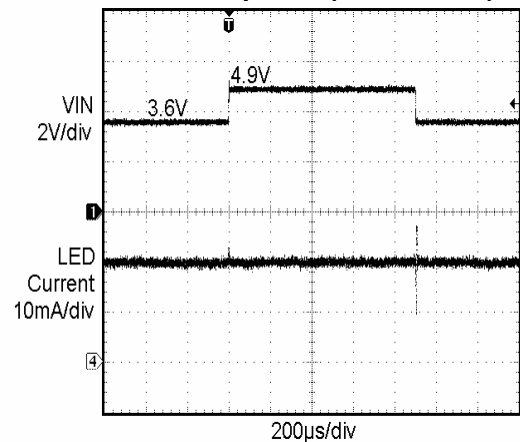

### TYPICAL PERFORMANCE CHARACTERISTICS

$V_{IN} = 3.6V$ ,  $I_{OUT} = 80mA$  (4 LEDs at 20mA),  $C_{IN} = C_{OUT} = C_1 = C_2 = 1\mu F$ ,  $T_{AMB} = 25^{\circ}C$  unless otherwise specified.

**Operating Waveforms in 1x Mode**

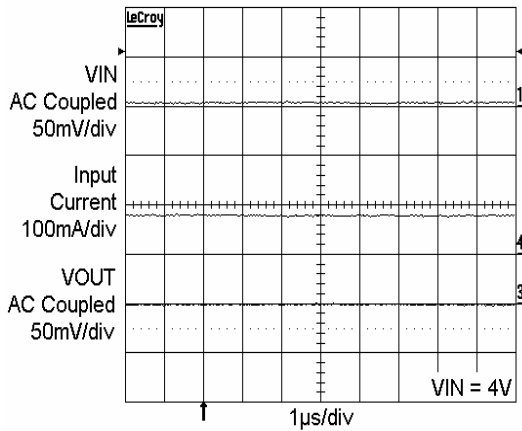

**Switching Waveforms in 1.33x Mode**

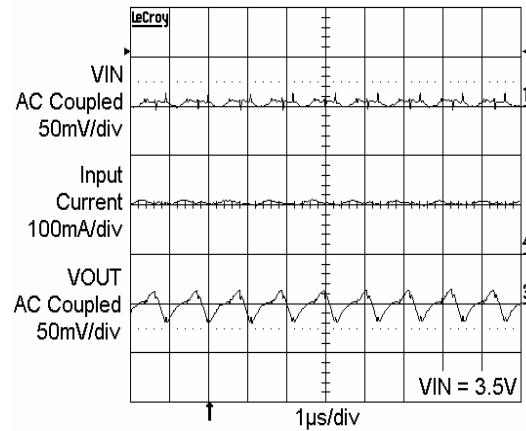

**Switching Waveforms in 1.5x Mode**

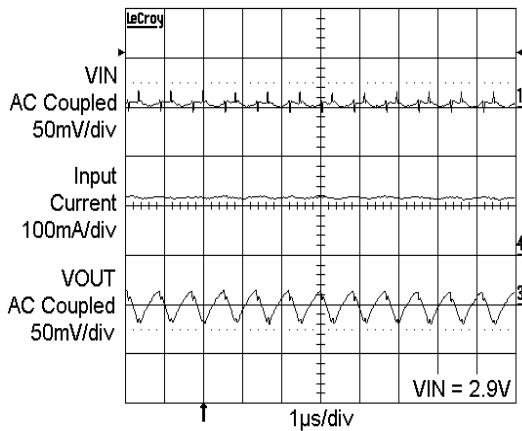

**Switching Waveforms in 2x Mode**

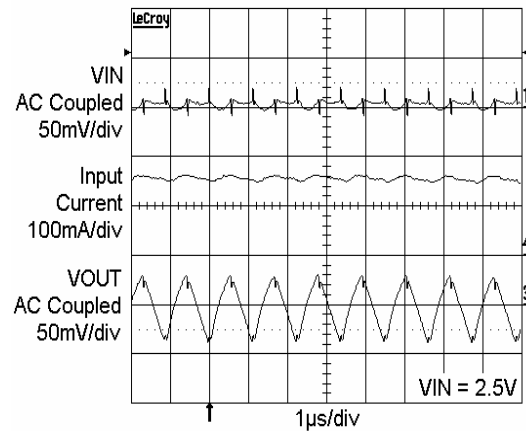

### TYPICAL PERFORMANCE CHARACTERISTICS

$V_{IN} = 3.6V$ ,  $I_{OUT} = 80mA$  (4 LEDs at 20mA),  $C_{IN} = C_{OUT} = C_1 = C_2 = 1\mu F$ ,  $T_{AMB} = 25^{\circ}C$  unless otherwise specified.

**Cold Power Up in 1x Mode**

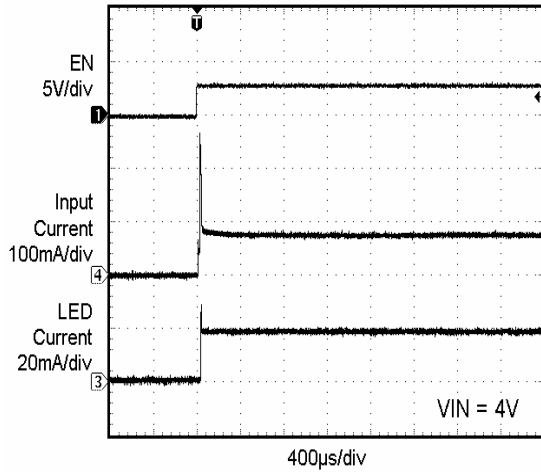

**Cold Power Up in 1.33x Mode**

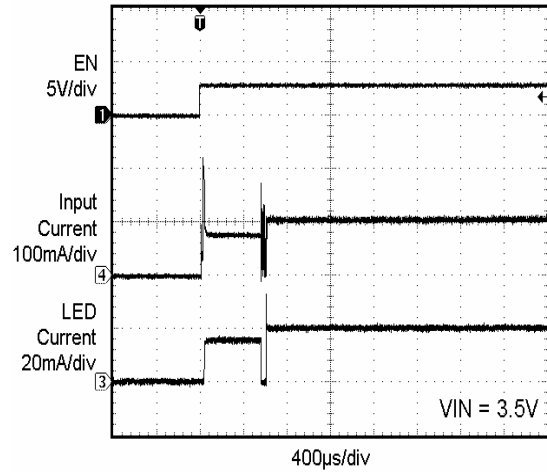

**Cold Power Up in 1.5x Mode**

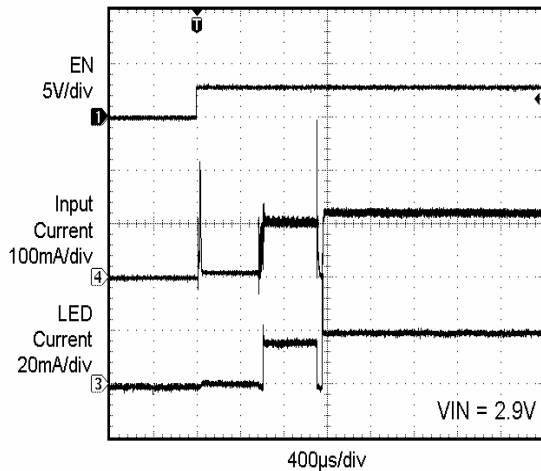

**Cold Power Up in 2x Mode**

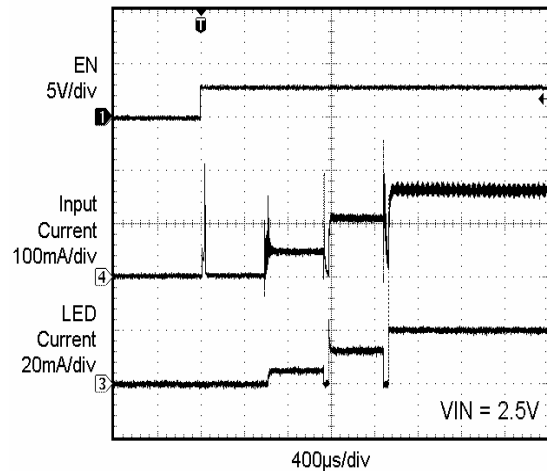

**Cold Power Up (1x Mode)**

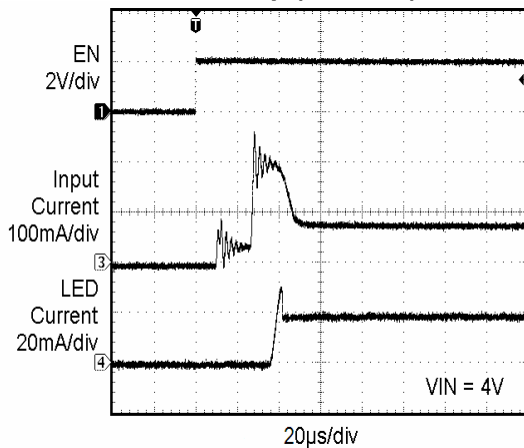

**Power Down (1x Mode)**

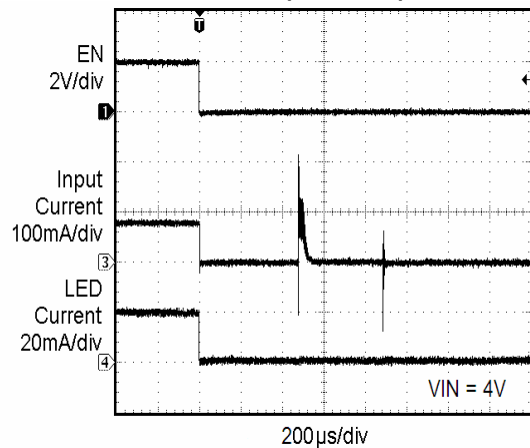

## PIN DESCRIPTION

Pin #	Name	Function
1	EN	Device enable (active high).
2	NC	Not connected inside the package.
3	NC	Not connected inside the package.
4	NC	Not connected inside the package.
5	RSET	Connect resistor RSET to set the LED current.
6	VOUT	Charge pump output connected to the LED anodes.
7	VIN	Charge pump input, connect to battery or supply.
8	C1+	Bucket capacitor 1 Positive terminal
9	C1-	Bucket capacitor 1 Negative terminal
10	C2-	Bucket capacitor 2 Negative terminal
11	C2+	Bucket capacitor 2 Positive terminal
12	GND	Ground Reference
13	LED4	LED4 cathode terminal.
14	LED3	LED3 cathode terminal.
15	LED2	LED2 cathode terminal.
16	LED1	LED1 cathode terminal.
TAB	GND	Connect to GND on the PCB.

## PIN FUNCTION

**VIN** is the supply pin for the charge pump. A small 1 $\mu$ F ceramic bypass capacitor is required between the VIN pin and ground near the device. The operating input voltage range is from 2.5V to 5.5V. Whenever the input supply falls below the under-voltage threshold (1.8V), all the LED channels are disabled and the device enters shutdown mode.

**EN** is the enable input and the high resolution PWM dimming control. Levels of logic high and logic low are set at 1.3V and 0.4V respectively. When EN is initially taken high, the device becomes enabled and all LED currents are set according to the R<sub>SET</sub> resistor. To place the device into “zero current” shutdown mode, the EN pin must be held low for at least 1.5ms.

**VOUT** is the charge pump output that is connected to the LED anodes. A small 1 $\mu$ F ceramic bypass capacitor is required between the V<sub>OUT</sub> pin and ground near the device.

**GND** is the ground reference for the charge pump. The pin must be connected to the ground plane on the PCB.

**C1+, C1-** are connected to each side of the ceramic bucket capacitor C<sub>1</sub>.

**C2+, C2-** are connected to each side of the ceramic bucket capacitor C<sub>2</sub>.

**LED1 to LED4** provide the internal regulated current source for each of the LED cathodes. These pins enter high-impedance zero current state whenever the device is placed in shutdown mode. If an LED pin is directly tied to VO<sub>UT</sub>, that channel is disabled.

**TAB** is the exposed pad underneath the package. For best thermal performance, the tab should be soldered to the PCB and connected to the ground plane.

**RSET** is connected to the resistor (R<sub>SET</sub>) to set the current for the LEDs. The voltage at this pin regulated to 0.6V. The ground side of the external resistor should be star connected back to the GND of the PCB. In shutdown mode, RSET becomes high impedance.

## BLOCK DIAGRAM

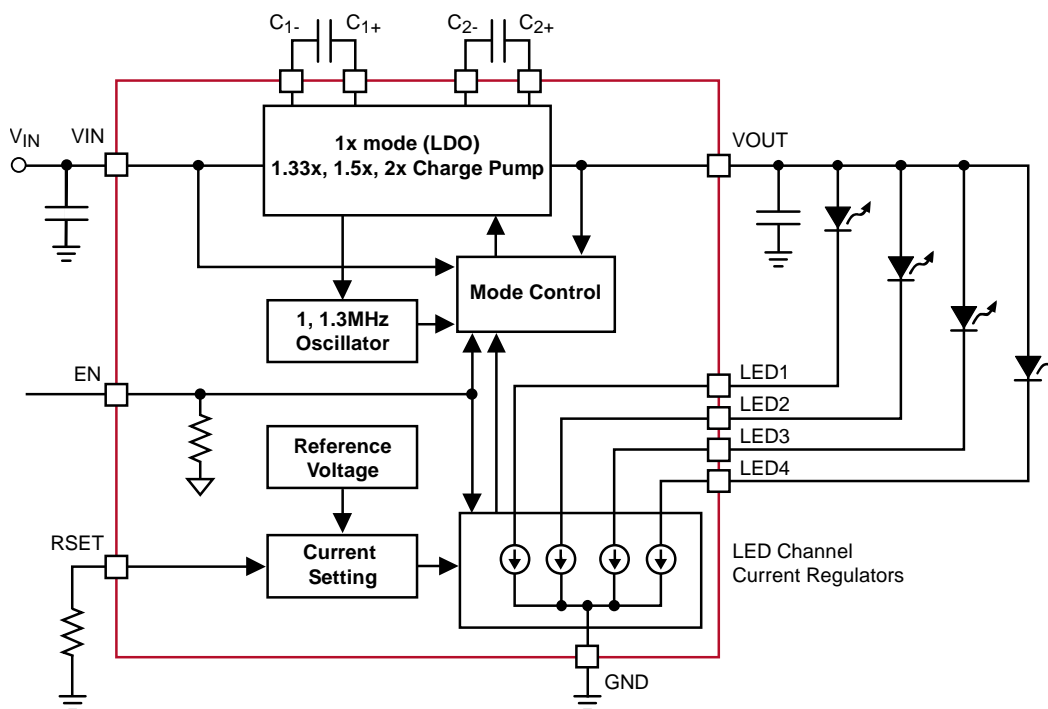

Figure 2. SET3604V Functional Block Diagram

## BASIC OPERATION

At power-up, the SET3604V starts operating in 1x mode where the output will be approximately equal to the input supply voltage (less any internal voltage losses). If the output voltage is sufficient to regulate all LED currents, the device remains in 1x operating mode.

If the input voltage is insufficient or falls to a level where the regulated currents cannot be maintained, the device automatically switches into 1.33x mode (after a fixed delay time of about 400µs). In 1.33x mode, the output voltage is approximately equal to 1.33 times the input supply voltage (less any internal voltage losses).

This sequence repeats in the 1.33x and 1.5x mode until the driver enters the 2x mode. In 1.5x mode, the output voltage is approximately equal to 1.5 times the input supply voltage. While in 2x mode, the output is approximately equal to 2 times the input supply voltage.

If the device detects a sufficient input voltage is present to drive all LED currents in 1x mode, it will change automatically back to 1x mode. This only applies for changing back to the 1x mode. The difference between the input voltage when exiting 1x

mode and returning to 1x mode is called the 1x mode transition hysteresis ( $V_{HYS}$ ) and is about 500mV

### LED Current Selection

The LED current is set to by the external resistor RSET as follows:

$$\text{LED current} = 132 \times \frac{0.6V}{R_{SET}}$$

The EN pin enables and disables the device. The LED driver enters a “zero current” shutdown mode if EN is held low for 1.5ms or more.

As soon as the EN input goes low, all LED channels are instantly disabled, where the LED current is set to zero. As long as the SET3604V is not in shutdown mode, the LEDs turn on as soon as the EN goes high.

## SET3604V

### Unused LED Channels

For applications not requiring all the channels, it is recommended to connect the unused LED pins directly to VOUT (see Figure 3).

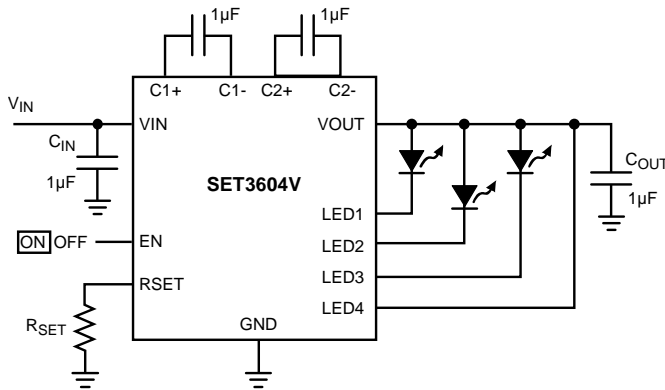

**Figure 3. Application with 3 LEDs**

### Protection Mode

If an LED is disconnected, the device senses that, run the diagnostics, then ignores that channel and goes back to the most effective mode. When all LEDs are disconnected, the device runs diagnostics and goes to 1x mode where the output is basically equal to the input voltage.

As soon as the output exceeds about 6V, the driver resets itself and reevaluate the mode.

If the die temperature reaches +150°C, the device enters a thermal protection shutdown mode. When the device temperature drops to about +130°C, the device resumes normal operation.

### LED Selection

LEDs with forward voltages ( $V_F$ ) ranging from 1.3V to 4.3V may be used. Selecting LEDs with lower  $V_F$  is recommended in order to extend battery life and keep the driver in 1x mode longer as the battery voltage decreases.

For example, if a 3.3V  $V_F$  LED is selected instead of a 3.5V  $V_F$  LED, the driver will stay in 1x mode for a lower supply voltage of 0.2V.

### External Components

The driver requires four external 1µF ceramic capacitors for decoupling input, output, and for the charge pump. Both capacitors type X5R and X7R are recommended for the LED driver application. In all charge pump modes, the input current ripple is kept very low by design and an input bypass capacitor of 1µF is sufficient.

In 1x mode, the device operates in linear mode and does not introduce switching noise back onto the supply.

### Recommended Layout

In charge pump mode, the driver switches internally at a high frequency. It is recommended to minimize trace length to all four capacitors. A ground plane should cover the area under the driver IC as well as the bypass capacitors. Short connection to ground on capacitors  $C_{IN}$  and  $C_{OUT}$  can be implemented with the use of multiple via. A copper area matching the TQFN exposed pad (TAB) must be connected to the ground plane underneath. The use of multiple via improves the package heat dissipation.

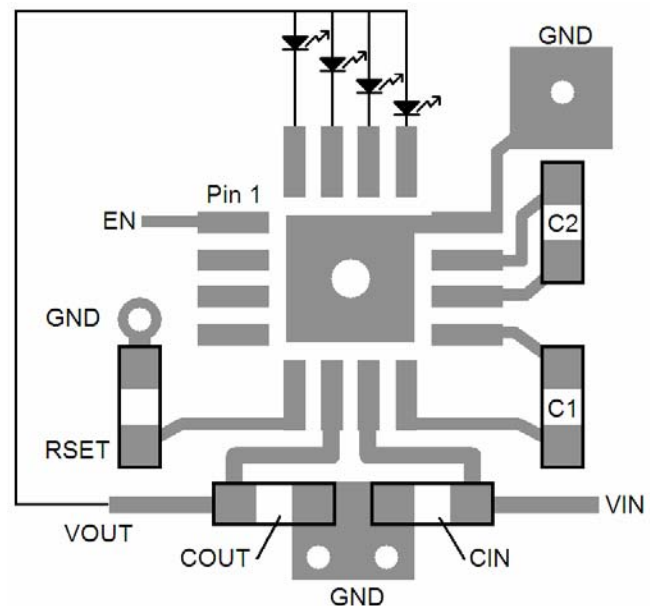

**Figure 4. PCB Layout**

## PWM DIMMING

The EN pin is used to provide total Shutdown of the device as well as High Resolution PWM dimming control on the LED Channels.

Shutdown of the device occurs after the EN pin has been held low for 1.5ms. During the “soft-start” power-up sequence from the shutdown mode, the LED current typically settles within 40 $\mu$ s (for 1X mode operation). This LED current settling time becomes 400 $\mu$ s if 1.33X operation is needed (i.e low battery voltage).

For High Resolution PWM dimming control (typically frequencies at 2kHz or above), the device will remain powered and only the LED channels output will be switched on and off during the PWM (the rest of the device will remain powered-up). This allows the output channels to have “instant-on” response, where the LED current settles within 1 $\mu$ s of the applied PWM dimming signals. This “instant-on” modes makes the device suitable for extremely high frequency PWM dimming schemes.

Figure 5 shows the output current for PWM frequencies up to 100kHz and with duty cycles of 30% and 70%.

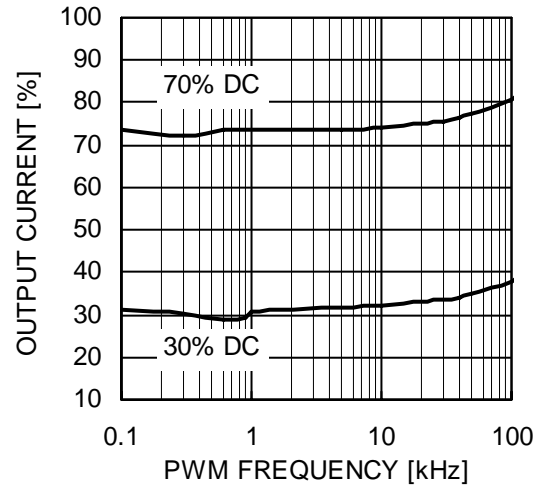

**Figure 5. Output current vs. PWM frequency**

For best performance, the duty cycle off-time  $T_{OFF}$  should meet the following timing limits:

- for slow frequency  $\leq 600\text{Hz}$ ,  $T_{OFF} \geq 800\mu\text{s}$
- for fast frequency  $\geq 1\text{kHz}$ ,  $T_{OFF} \leq 400\mu\text{s}$

**TYPICAL PERFORMANCE CHARACTERISTICS**

$V_{IN} = 3.6V$ ,  $I_{OUT} = 80mA$  (4 LEDs at 20mA),  $C_{IN} = C_{OUT} = C_1 = C_2 = 1\mu F$ ,  $T_{AMB} = 25^{\circ}C$  unless otherwise specified.

**10kHz PWM waveform (1x mode)**

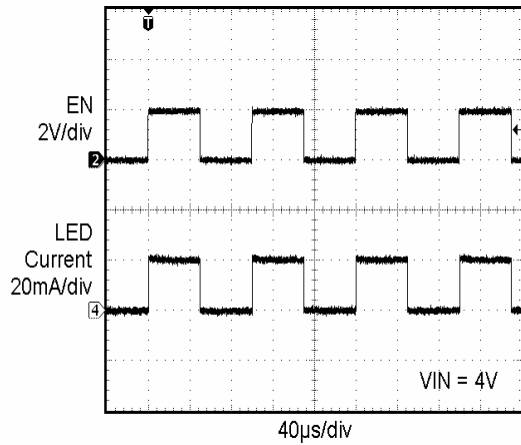

**10kHz PWM waveform (1.33x mode)**

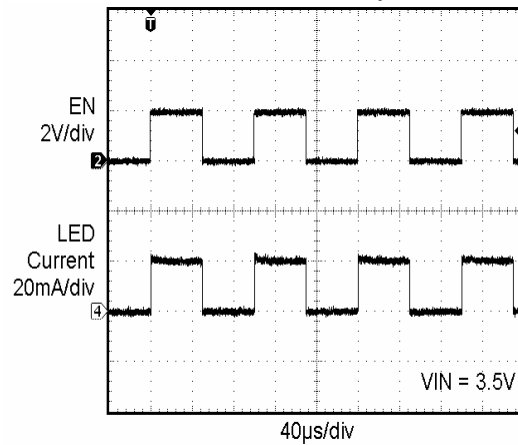

**300Hz PWM waveform (1x mode)**

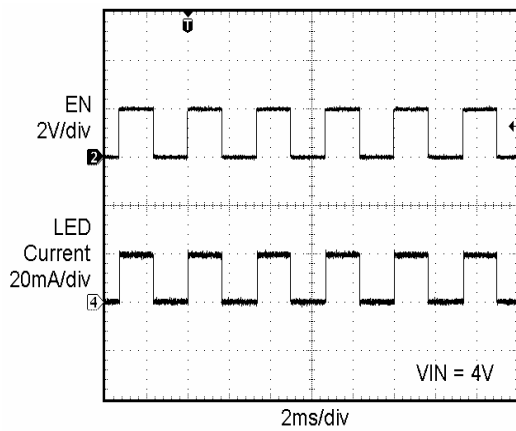

**Dimming Linearity, PWM at 200Hz**

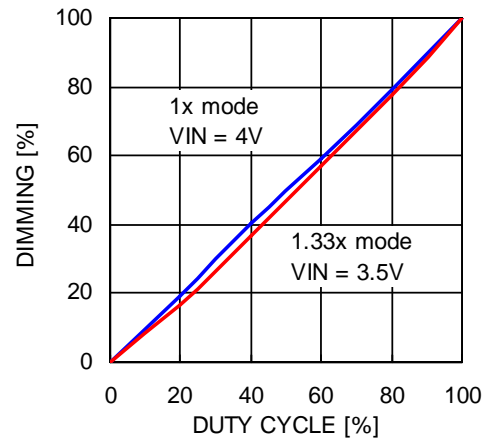

**Dimming Linearity, PWM at 500Hz**

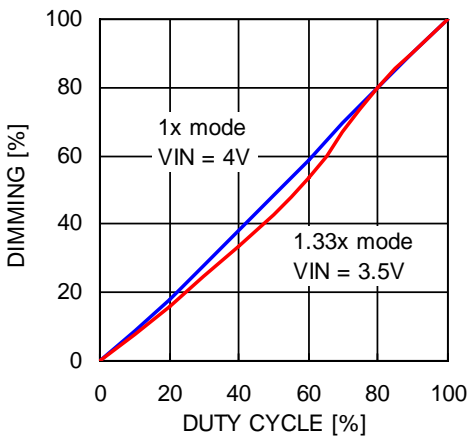

**Dimming Linearity, PWM at 30kHz**

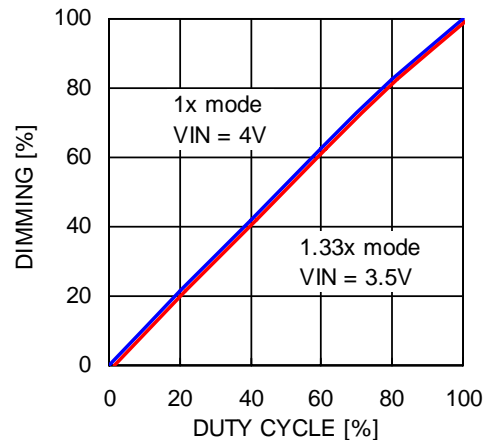

**PACKAGE OUTLINE DRAWING**

TQFN 16-Pad 4 x 4mm (HV4)<sup>(1)(2)</sup>

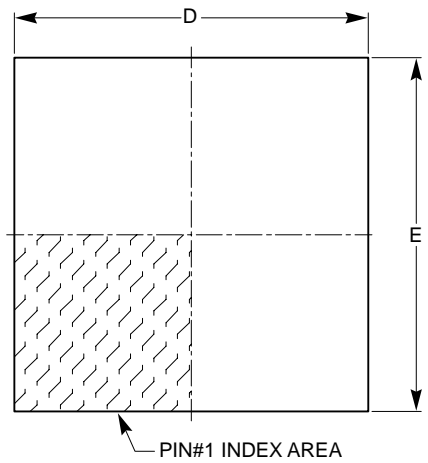

TOP VIEW

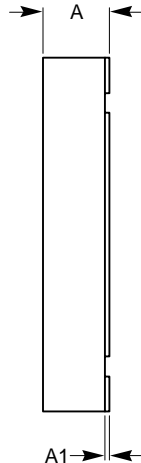

SIDE VIEW

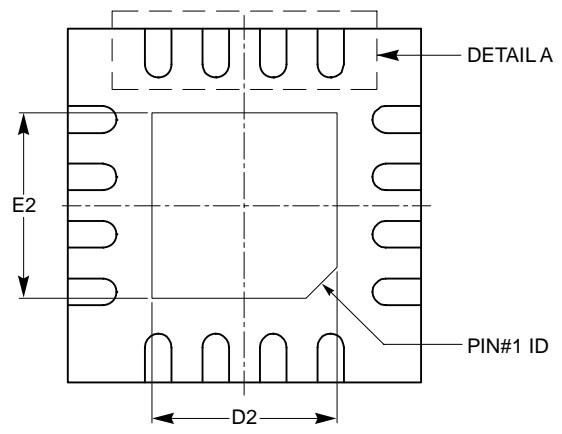

BOTTOM VIEW

SYMBOL	MIN	NOM	MAX
A	0.70	0.75	0.80
A1	0.00	0.02	0.05
A3	0.20 REF		
b	0.25	0.30	0.35
D	3.90	4.00	4.10
D2	2.00	-	2.90
E	3.90	4.00	4.10
E2	2.00	-	2.90
e	0.65 BSC		
L	0.30	-	0.60

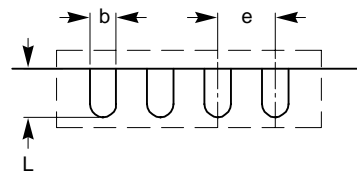

DETAIL A

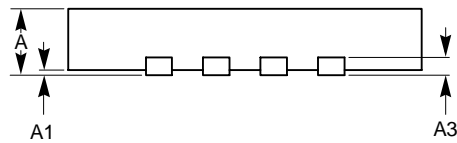

FRONT VIEW

**Notes:**

- (1) All dimensions are in millimeters.
- (2) Complies with JEDEC standard MO-220.

**EXAMPLE OF ORDERING INFORMATION**

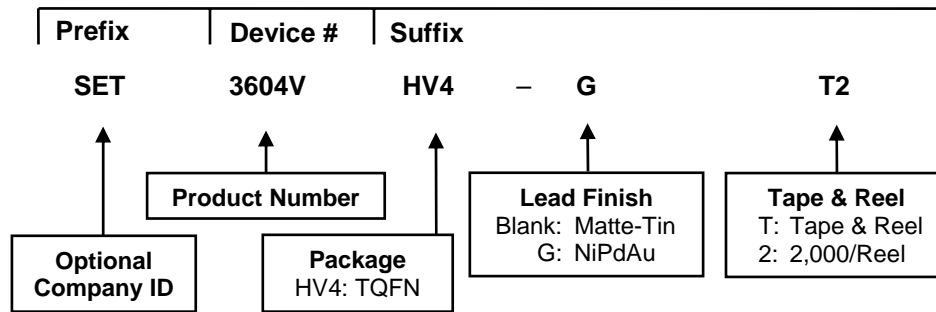

**Notes:**

- (1) All packages are RoHS-compliant (Lead-free, Halogen-free).
- (2) The standard lead finish is NiPdAu.
- (3) The device used in the above example is a SET3604VHV4-GT2 (TQFN, Tape & Reel, 2,000/Reel).
- (4) For additional package and temperature options, please contact your nearest Semitel sales office.



Semitel Electronics Co., Ltd.  
 Flat C, 9/F, Unison Industrial Centre, 27-31 AuPuiWan Street,  
 Fotan, Shatin, Hong Kong  
 Tel: +852-3527 3141  
 Fax: +852-2127 7623